

Model 142

Little Softy Soft Serve Freezer

Operating Instructions

039709-M



3/00

Complete this page for quick reference when service is required:

Taylor Distributor: _____

Address: _____

Phone: _____

Service: _____

Parts: _____

Date of Installation: _____

Information found on the data label:

Model Number: _____

Serial Number: _____

Electrical Specs: Voltage _____ Cycle _____

Phase _____

Maximum Fuse Size: _____ A

Minimum Wire Ampacity: _____ A

© March, 2000 Taylor
All rights reserved.
039709-M



The word Taylor and the Crown design are registered trademarks in the United States of America and certain other countries.

Taylor Company
750 N. Blackhawk Blvd.
Rockton, IL 61072

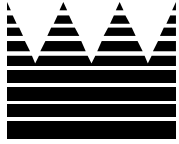

Table of Contents

Section 1	To the Installer	1
	Electrical Hook-up Installation	
	For 60 Cycle, 1 Phase, Supplied With Cord and Plug	1
Section 2	To the Operator	2
	Compressor Warranty Disclaimer	2
Section 3	Safety	3
Section 4	Operator Parts Identification	4
Section 5	Important: To the Operator	5
	Symbol Definitions	5
	Power Switch	5
	Indicator Light - MIX LOW	6
	Standby Switch	6
	Reset Mechanism	6
	Temperature Adjustments	6
	Feed Tube	6
Section 6	Operating Procedures	7
	Assembly	7
	Sanitizing	10
	Priming	12
	Standby	13
	Closing Procedure	13
	Draining Product From the Freezing Cylinder	13
	Rinsing	13
	Cleaning	14
	Disassembly	14
	Brush Cleaning	14
Section 7	Important: Operator Checklist	16
	During Cleaning and Sanitizing:	16
	Troubleshooting Bacterial Count:	16
	Regular Maintenance Checks:	16
	Winter Storage	17
Section 8	Troubleshooting Guide	18
Section 9	Parts Replacement Schedule	20
Section 10	Parts List	21
	Wiring Diagram	26

Note: Continuing research results in steady improvements; therefore, information in this manual is subject to change without notice.

Section 1

To the Installer

These machines are designed for indoor use only.



DO NOT install the machines in an area where a water jet could be used. Failure to follow this instruction may result in serious electrical shock.

Air Cooled Units

Air cooled units require a minimum of 6" (152 mm) of clearance on both sides and 4" (102 mm) of clearance on the bottom of the freezer. To prevent warm exhaust from recirculating, place the rear of the unit against the wall. This will allow adequate air flow across the condenser.

Electrical Connections

Each freezer requires one power supply for each data label. Check the data label(s) on the freezer for fuse, circuit ampacity and electrical specifications. Refer to the wiring diagram provided inside of the electrical box, for proper power connections.

In the United States, this equipment is intended to be installed in accordance with the National Electrical Code (NEC), ANSI/NFPA 70-1987. The purpose of the NEC code is the practical safeguarding of persons and property from hazards arising from the use of electricity. This code contains provisions considered necessary for safety. Compliance therewith and proper maintenance will result in an installation essentially free from hazard!

In all other areas of the world, equipment should be installed in accordance with the existing local codes. Please contact your local authorities.

Stationary appliances which are not equipped with a power cord and a plug or other device to disconnect the appliance from the power source must have an all-pole disconnecting device with a contact gap of at least 3 mm installed in the external installation.



CAUTION: This equipment must be properly grounded! Failure to do so can result in severe personal injury from electrical shock!

Electrical Hook-up Installation

For 60 Cycle, 1 PH, Supplied With Cord and Plug

This equipment is supplied with a 3-wire cord and grounding type plug for connection to a single phase, 60 cycle, branch circuit supply. This unit must be plugged into a properly grounded receptacle. The cord and plug provided for 115/60/1 and 208-230/60/1 is 15 amp.; therefore the wall outlet must also be 15 amp. Check the data label located on the rear of the freezer for electrical specifications.

IMPORTANT: In order to secure the compressor and to minimize vibration during shipment, two shipping bolts have been added to the base pan of the unit. Before installation, these bolts must be removed.

Permanent wiring may be used if local codes require it. Instructions for conversion to permanent wiring are as follows:



IMPORTANT: This procedure must be performed by a qualified electrician.

1. Be sure the freezer is electrically disconnected.
2. Remove the appropriate panel and locate the control box at the back of the freezer.
3. Remove the factory-installed cord and strain relief bushing.
4. Route incoming permanent wiring through 7/8" (22 mm) hole in base pan.
5. Connect two power supply leads, attach ground (earth) wire to the grounding lug inside the electrical box.
6. Be sure unit is properly grounded before applying power.



FOLLOW YOUR LOCAL ELECTRICAL CODES!

Section 2

To the Operator

Your freezer has been carefully engineered and manufactured to give you dependable operation. If the Taylor Model 142 is properly operated and cared for, it will produce a consistent, quality product. Like all mechanical products, this machine will require cleaning and maintenance. A minimum amount of care is necessary if the operating procedures outlined in this manual are followed closely.

This Operator's Manual should be read before operating or performing any maintenance on your equipment.

Your Taylor freezer will NOT eventually compensate and correct for any errors during the set-up or filling operations. Thus, the initial assembly and priming procedures are of extreme importance. It is important that the personnel responsible for the equipment's operation study this manual in order to be properly trained.

If you require technical assistance, please contact your authorized Taylor Distributor.



If the crossed out wheeled bin symbol is affixed to this product, it signifies that this product is compliant with the EU Directive as well as other similar legislation in effect after August 13, 2005. Therefore, it must be collected separately after its use is completed, and cannot be disposed as unsorted municipal waste.

The user is responsible for returning the product to the appropriate collection facility, as specified by your local code.

For additional information regarding applicable local laws, please contact the municipal facility and/or local distributor.

Compressor Warranty Disclaimer

The refrigeration compressor(s) on this machine are warranted for the term indicated on the warranty card accompanying this machine. However, due to the Montreal Protocol and the U.S. Clean Air Act Amendments of 1990, many new refrigerants are being tested and developed, thus seeking their way into the service industry. Some of these new refrigerants are being advertised as drop-in replacements for numerous applications. It should be noted that, in the event of ordinary service to this machine's refrigeration system, **only the refrigerant specified on the affixed data label should be used.** The unauthorized use of alternate refrigerants will void your compressor warranty. It will be the owner's responsibility to make this fact known to any technician he employs.

It should also be noted that Taylor does not warrant the refrigerant used in its equipment. For example, if the refrigerant is lost during the course of ordinary service to this machine, Taylor has no obligation to either supply or provide its replacement either at billable or unbillable terms. Taylor does have the obligation to recommend a suitable replacement if the original refrigerant is banned, obsoleted, or no longer available during the five year warranty of the compressor.

The Taylor Company will continue to monitor the industry and test new alternates as they are being developed. Should a new alternate prove, through our testing, that it would be accepted as a drop-in replacement, then the above disclaimer would become null and void. To find out the current status of an alternate refrigerant as it relates to your compressor warranty, call the local Taylor Distributor or the Taylor Factory. Be prepared to provide the Model/Serial Number of the unit in question.

We at Taylor Company are concerned about the safety of the operator when he or she comes in contact with the freezer and its parts. Taylor has gone to extreme efforts to design and manufacture built-in safety features to protect both you and the service technician. As an example, warning labels have been attached to the freezer to further point out safety precautions to the operator.



IMPORTANT - Failure to adhere to the following safety precautions may result in severe personal injury. Failure to comply with these warnings may damage the machine and its components. Component damage will result in part replacement expense and service repair expense.

To Operate Safely:



DO NOT operate the freezer without reading this operator's manual. Failure to follow this instruction may result in equipment damage, poor freezer performance, health hazards, or personal injury.



- **DO NOT** operate the freezer unless it is properly grounded.
- **DO NOT** operate the freezer with larger fuses than specified on the freezer data label.
- **DO NOT** attempt any repairs unless the main power supply to the freezer has been disconnected.

Failure to follow these instructions may result in electrocution. Contact your local authorized Taylor Distributor for service.



DO NOT use a water jet to clean or rinse the freezer. Failure to follow these instructions may result in serious electrical shock.



- **DO NOT** allow untrained personnel to operate this machine.
- **DO NOT** put objects or fingers in the dispensing spout.
- **DO NOT** operate the freezer unless all service panels and access doors are restrained with screws.
- **DO NOT** remove the freezer door or beater assembly unless the power switch is in the "OFF" position.

Failure to follow these instructions may result in severe personal injury from hazardous moving parts.



USE EXTREME CAUTION when removing the beater assembly. The scraper blades are very sharp and may cause injury.



This freezer must be placed on a level surface. Failure to comply may result in personal injury or equipment damage.

DO NOT obstruct air intake and discharge openings: 6" (152 mm) minimum air space on sides and rear, and 4" (102 mm) minimum on bottom. Failure to follow this instruction may cause poor freezer performance and damage to the machine.

This freezer is designed to operate indoors, under normal ambient temperatures of 70°-75°F (21°-24°C). The freezer has successfully performed in high ambient temperatures of 104°F (40°C) at reduced capacity.

NOISE LEVEL: Airborne noise emission does not exceed 78 dB(A) when measured at a distance of 1.0 meter from the surface of the machine and at a height of 1.6 meters from the floor.

Section 4

Operator Parts Identification

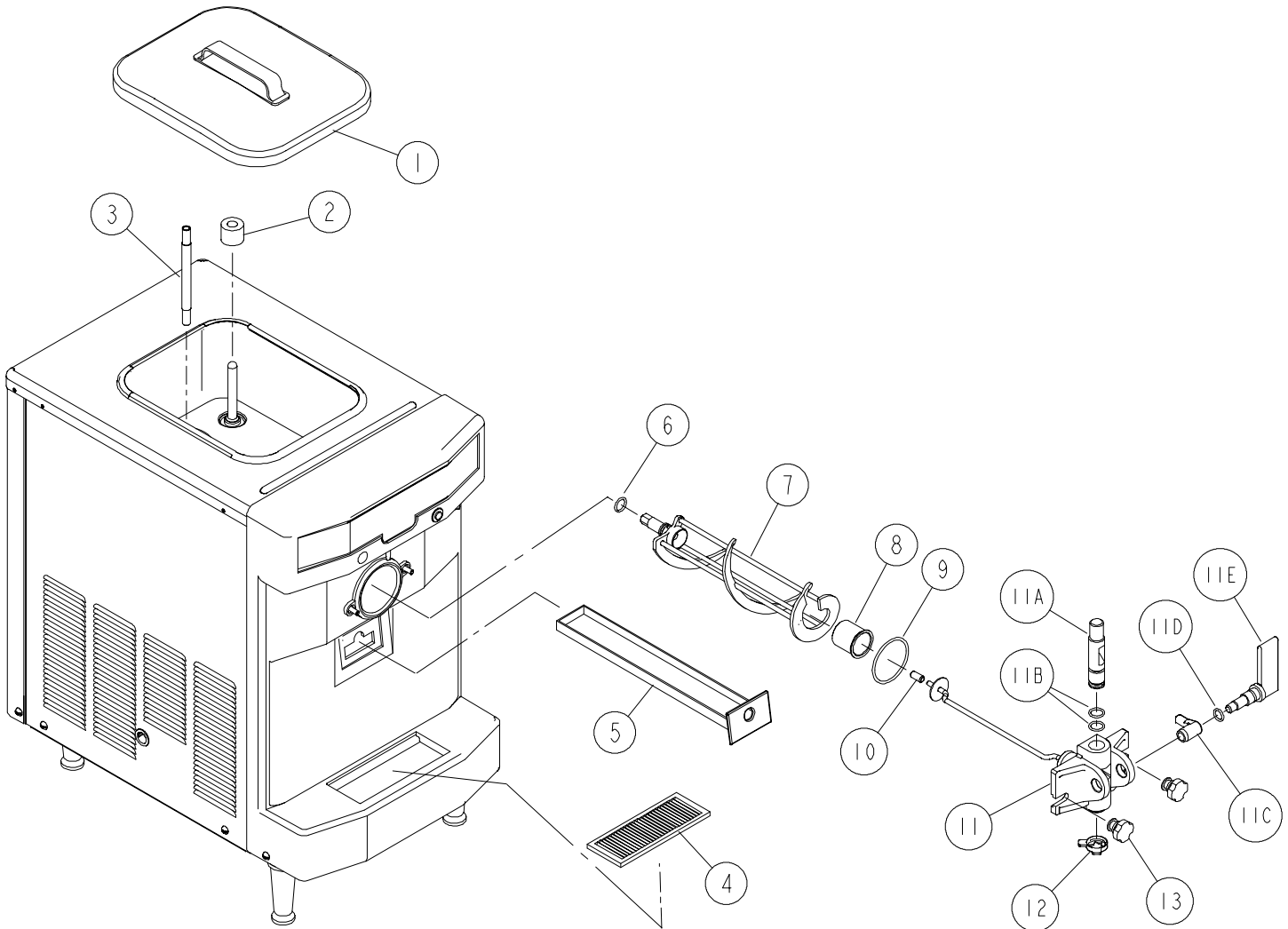

ITEM	DESCRIPTION	PART NO.
1	Hopper Cover	X49633
2	Float-Mix Level	X39690
3	Feed Tube	035819
4	Splash Shield	039444
5	Drip Pan	X43474
6	O-Ring	021278
7	Beater	X24689
8	Front Bearing	023262
9	O-Ring 2-3/4 OD x .139W	019998

ITEM	DESCRIPTION	PART NO.
10	Bearing Guide	014496
11	Door A.-1 Spout	X38959-SER
11A	Draw Valve	024763
11B	O-Ring 7/8 OD x .103W	014402
11C	Valve Lifter Arm	024761
11D	O-Ring 3/4 OD x .103	015835
11E	Door Handle	024762
12	Design Cap	014218
13	Stud Nut	034829

Section 5

Important: To the Operator

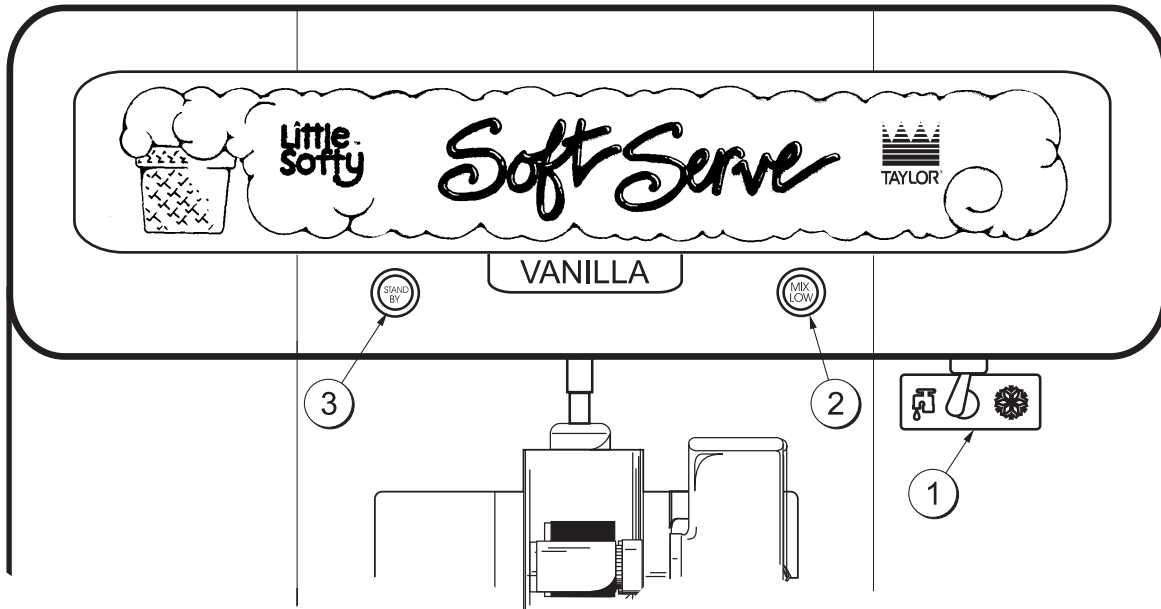





Figure 1

ITEM	DESCRIPTION
1	Power Switch
2	Indicator Light - MIX LOW
3	Standby Switch

The following chart identifies the symbol definitions used on the operator switches.

-  = ON/AUTO
-  = OFF
-  = WASH

Symbol Definitions

To better communicate in the International arena, the words on many of our operator switches and buttons have symbols to indicate their functions. Your Taylor equipment is designed with these International symbols.

Power Switch

The center position is the OFF position. The left position is WASH which activates the beater motor only. The right position is the AUTO position, which activates the beater motor and the refrigeration.

Indicator Light - MIX LOW

A mix level indicating light is located on the front of the machine. When the light is on, it indicates that the mix hopper has a low supply of mix. The hopper should be refilled immediately. Always maintain at least 2" (5.1 cm.) of mix in the hopper. If mix is not added to the hopper, the freezing cylinder may freeze. This will cause damage to the beater assembly and to the freezer door.

Standby Switch

This push button switch determines which mode of operation the freezing cylinder is operating in. If the center button of this switch is in the "OUT" position and it is not illuminated, the unit will operate in the normal product dispensing mode when the toggle switch is placed in the AUTO position.

If the center button of the standby switch is in the "IN" position and is illuminated, the machine will operate in the STANDBY mode when the toggle switch is placed in the AUTO position.

Reset Mechanism

Should an overload condition occur, the freezer will automatically shut down. To properly reset the freezer, place the toggle switch in the OFF position. Wait two or three minutes; then press the reset button located in the side panel. Place the toggle switch in the WASH position and observe the freezer's performance; return the toggle switch to the AUTO position.

Temperature Adjustments

Temperature adjustments should be performed only by an authorized Taylor Service Representative.

Feed Tube

The feed tube meters a combination of mix and air into the freezing cylinder. If mix is not added to the hopper, the freezing cylinder may freeze. This will cause damage to the beater assembly and to the freezer door. Depending upon the product being run, you may wish to contact your local authorized Taylor Distributor to make a slight adjustment in the feed tube.

When the unit is operating in the AUTO mode, the metering hole should be placed in the downward position. When the unit is placed in the STANDBY mode, the tube should be inverted.

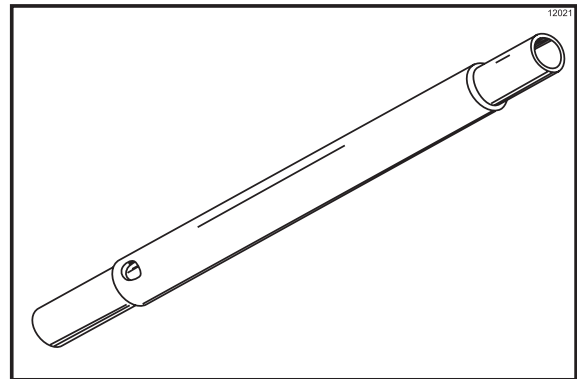

Figure 2

Section 6

Operating Procedures

The Model 142 has a 1.5 quart (1.4 liter) capacity freezing cylinder. The mix flows from the hopper to the freezing cylinder through a feed tube. The mix flow is controlled by gravity.

We begin our instructions at the point where we enter the store in the morning and find the parts disassembled and laid out to air dry from the previous night's cleaning.

These opening procedures will show you how to assemble these parts into the freezer, sanitize them and prime the freezer with fresh mix in preparation to serve your first portion.

If you are disassembling the machine for the first time or need information to get to the starting point in our instructions, turn to page 14 "Disassembly", and start there.

Assembly

Note: Use an approved food grade lubricant (example: Taylor Lube) when lubricating parts.

Step 1

Install the beater assembly. Place lubricant inside the groove, then slide the small, thick o-ring into the groove on the drive shaft of the beater assembly. Apply an even coat of Taylor Lube to the o-ring and shaft. **Do not lubricate the hex end.**

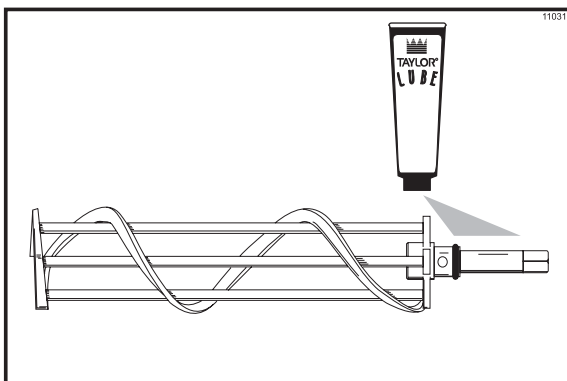

Figure 3

Insert the beater assembly and allow the drive shaft to travel through the rear shell bearing at the back of the freezing cylinder, and engage the hex end of the drive shaft firmly into the female socket. When installed properly, the beater will not protrude beyond the front of the freezing cylinder.

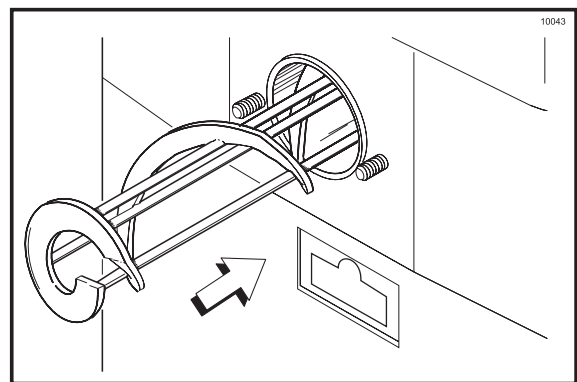

Figure 4

Step 2

Assemble the freezer door. Place the large o-ring into the groove on the back of the freezer door and lubricate with Taylor Lube.

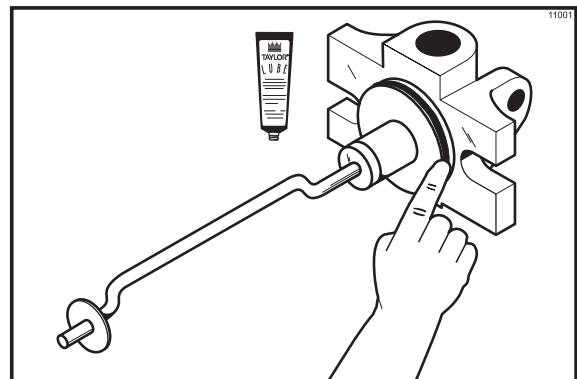

Figure 5

Slide the front bearing over the baffle rod so the flanged edge is against the door. Place the white plastic guide bearing on the end of the baffle rod. **Do not lubricate the front bearing or guide bearing.**

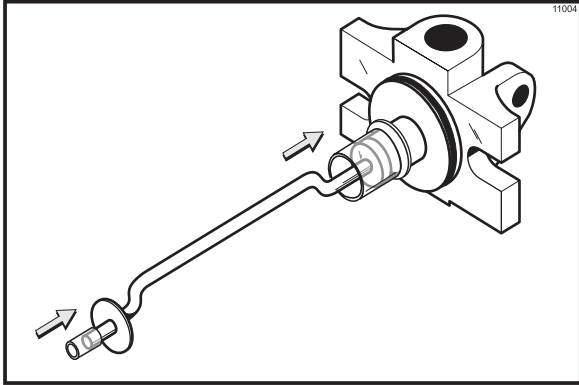

Figure 6

Step 3

Install the freezer door. Insert the handscrews into the slots in the freezer door. With both hands holding the sides of the freezer door, insert the baffle rod into the center of the beater assembly. The white guide bearing must fit securely in the hole of the drive shaft. Finger-tighten the handscrews equally to ensure that the door is snug. **Do not over-tighten.**

Note: The freezer door is in the correct position when the door spout is on the bottom.

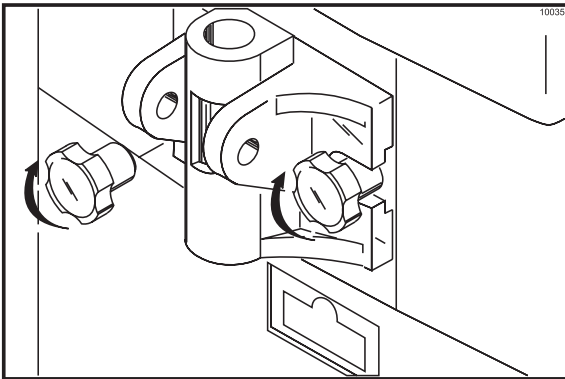

Figure 7

Step 4

Install the draw valve. Slide the two o-rings into the grooves on the draw valve and lubricate with Taylor Lube.

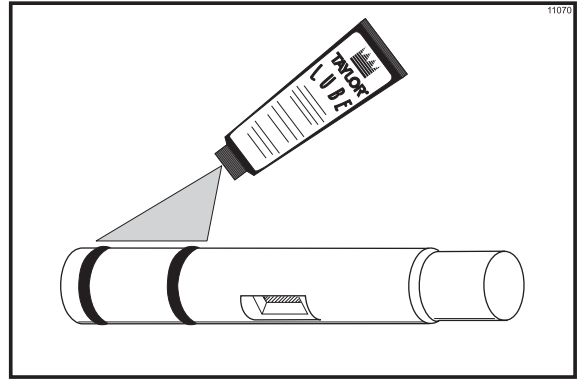

Figure 8

Lubricate the inside of the door spout from the **bottom**. Insert the draw valve into the freezer door from the **bottom**.

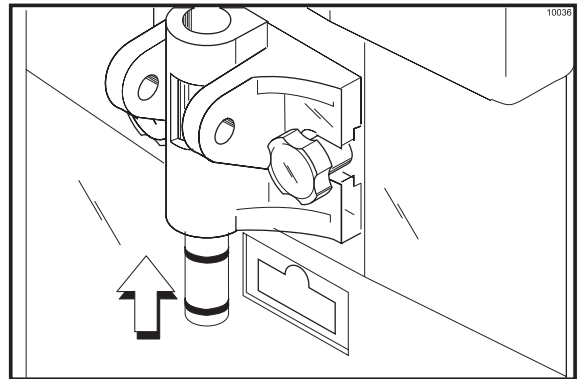

Figure 9

Note: The draw valve is installed correctly when the slotted opening in the draw valve is visible through the “window” of the freezer door.

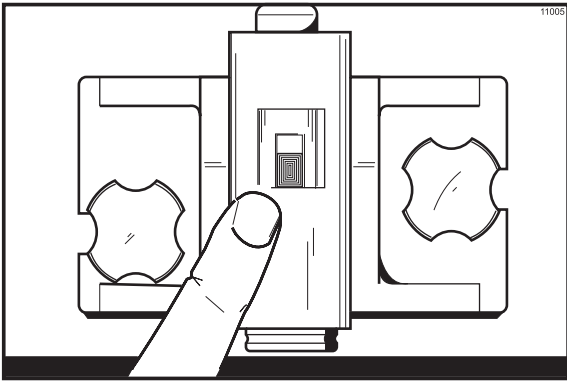

Figure 10

Step 5

Install the draw valve handle. Insert the valve lifter arm through the slotted opening in the draw valve and align the other end with the cross holes of the freezer door.

Note: The valve lifter arm may be aligned with the left or the right cross hole. The draw valve handle will be placed through the opposite cross hole of the valve lifter arm.

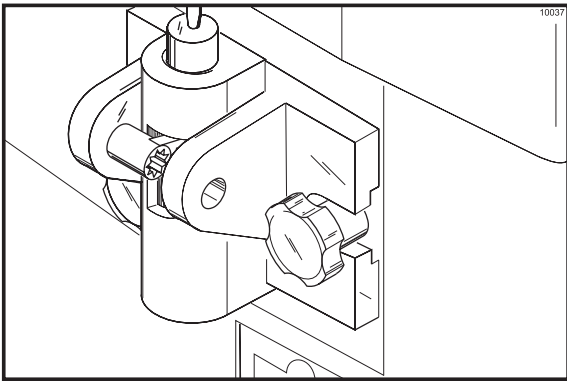

Figure 11

Slide the o-ring into the groove on the draw valve handle and lubricate with Taylor Lube.

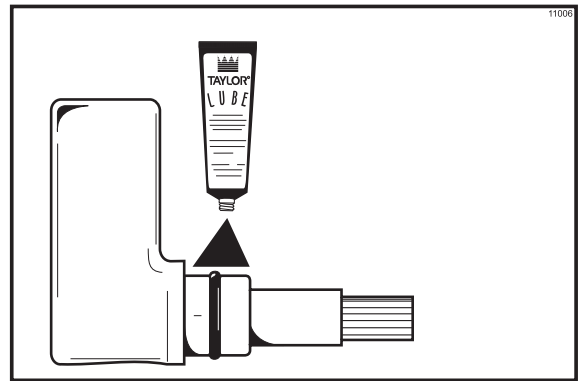

Figure 12

Insert the draw valve handle through the opposite cross hole and into the opening of the valve lifter arm.

Note: The draw valve handle can be assembled at varied vertical positions. Choose an angle which is comfortable for you, making sure the draw valve is completely raised when the draw valve handle is completely down.

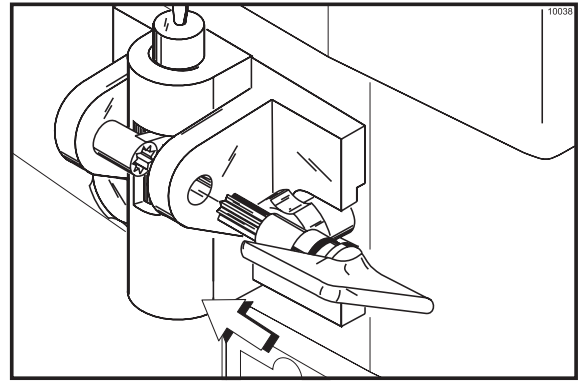

Figure 13

The illustration below shows the draw valve assembled on the left side.

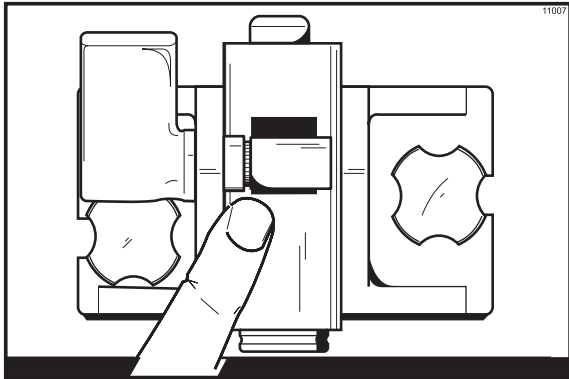

Figure 14

Step 6
Snap the design cap over the bottom of the freezer door spout.

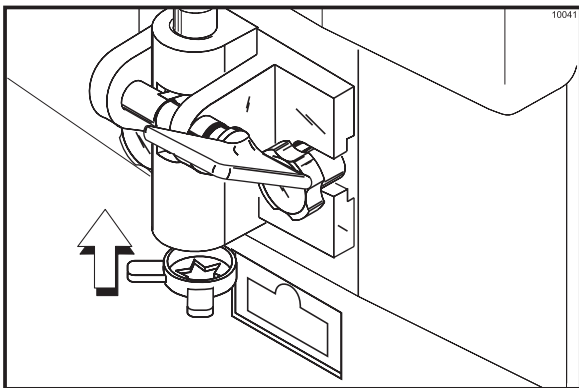

Figure 15

Step 7
Lay the feed tube and mix level float in the bottom of the mix hopper.

Sanitizing

Step 1

Prepare one gallon (3.8 liters) of an approved 100 PPM sanitizing solution (example: Kay-5®). USE WARM WATER AND FOLLOW THE MANUFACTURER'S SPECIFICATIONS.

Step 2

Pour the one gallon (3.8 liters) of sanitizing solution into the hopper and allow it to flow into the freezing cylinder.

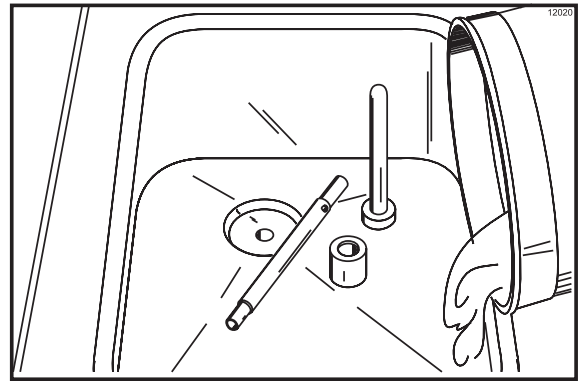

Figure 16

Step 3

While the solution is flowing into the freezing cylinder, brush-clean the mix hopper, mix level float stem, mix level float, mix inlet hole, and air tube.

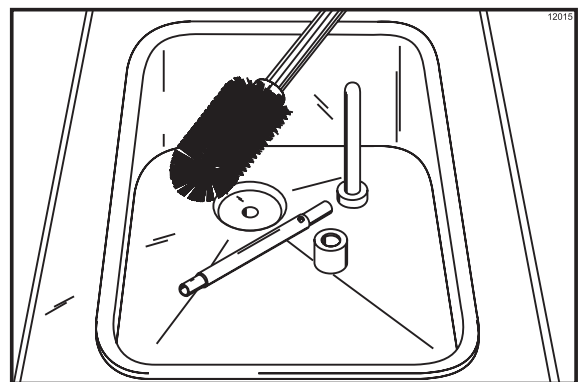

Figure 17

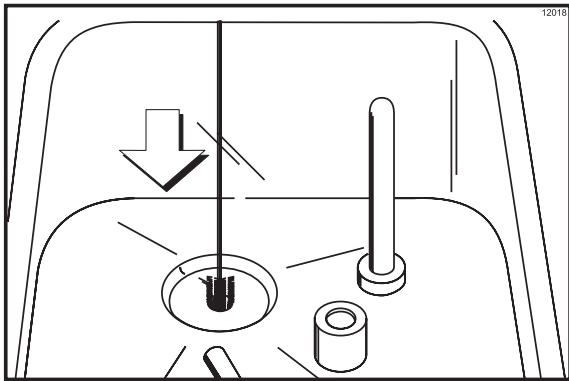

Figure 18

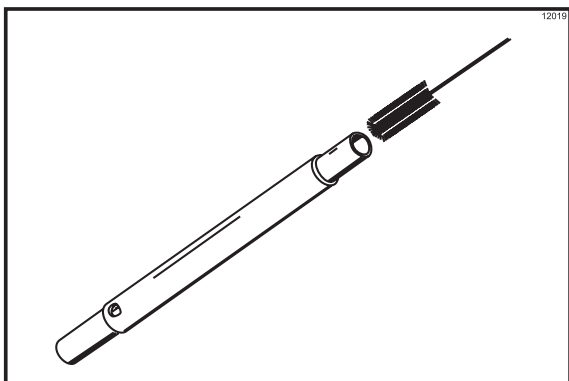

Figure 19

Step 4

Place the toggle switch in the WASH position. This will cause the sanitizing solution in the freezing cylinder to be agitated. Allow to agitate for five minutes.

Step 5

Place an empty pail beneath the door spout and open the draw valve. Draw off all the sanitizing solution. When the sanitizer stops flowing from the door spout, close the draw valve and place the toggle switch in the OFF position.

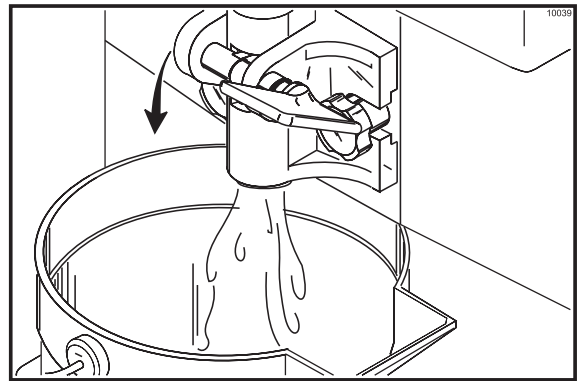

Figure 20

Step 6

Remove the feed tube from the hopper. (Be sure your hands are sanitized.)

Step 7

Place the mix level float on the mix level float stem.

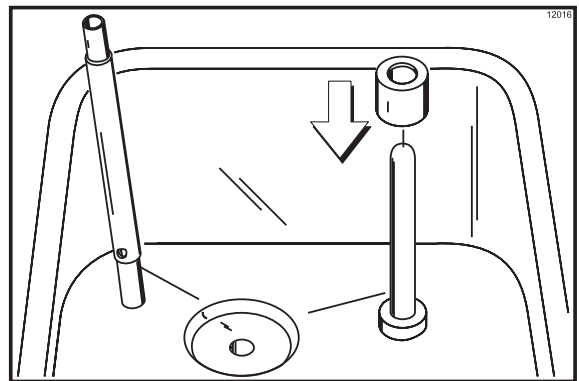

Figure 21

Priming

Prime the machine as close as possible to the time of first product draw.

Step 1

With a pail beneath the door spout, open the draw valve. Fill the mix hopper with FRESH mix and allow it to flow into the freezing cylinder. This will force out any remaining sanitizing solution. When full strength mix is flowing from the door spout, close the draw valve.

Note: Use only fresh mix when priming the freezer.

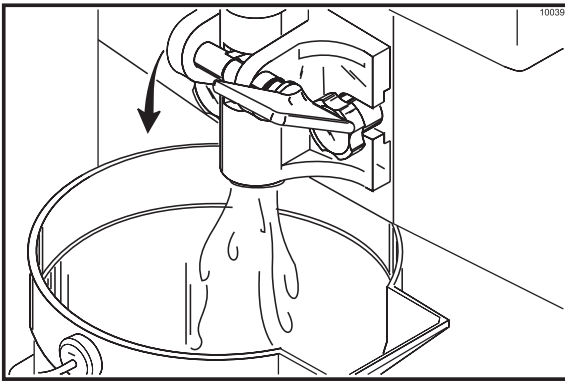

Figure 22

Step 2

When the mix has stopped bubbling down into the freezing cylinder, install the feed tube in the mix inlet hole.

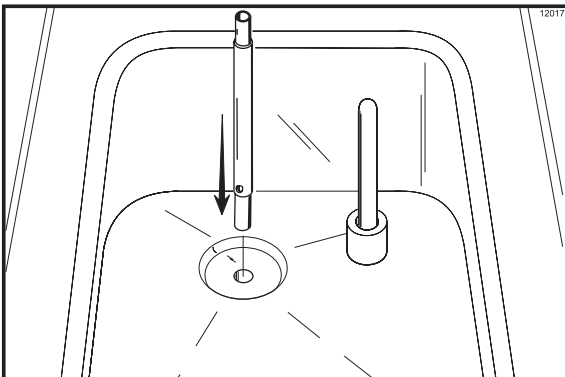

Figure 23

Step 3

Place the toggle switch in the AUTO position. When the unit cycles off, the product will be ready to serve.

Step 4

Place the mix hopper cover in position.

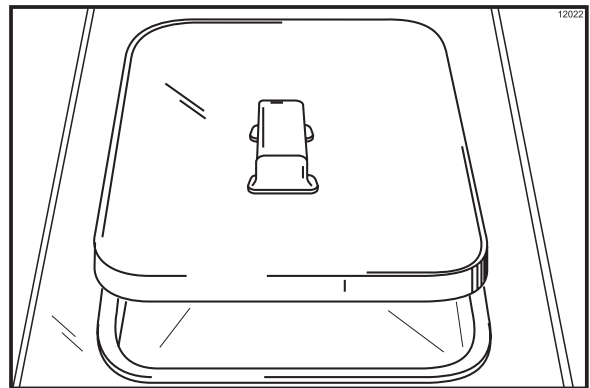

Figure 24

Step 5

Install the splash shield under the freezer door.

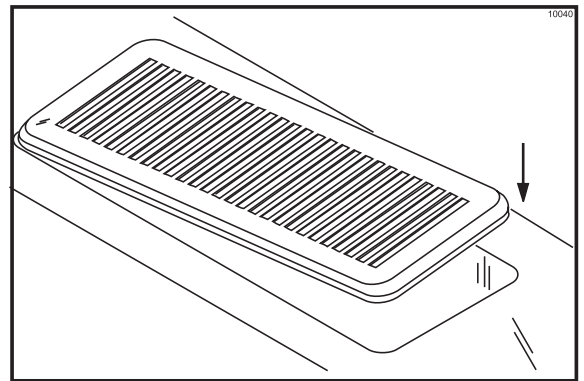

Figure 25

Step 6

Slide the rear drip pan into the hole in the front panel.

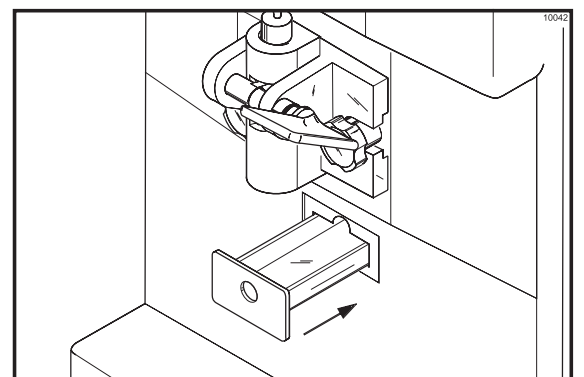

Figure 26

Standby

This unit is equipped with a STANDBY feature. If product is not dispensed for long periods of time (i.e.; early morning hours), the STANDBY feature will maintain the hopper and freezing cylinder product at safe temperatures, and prevent product breakdown.

To use the standby feature, perform the following steps:

Step 1

Verify that the hopper is adequately filled with mix, and invert the feed tube.

Step 2

Place the power switch in the AUTO position, and press the STANDBY button. The button will light, indicating that the unit is operating as a refrigerator for product in the hopper and freezing cylinder.

Step 3

To remove the unit from the STANDBY mode, place the power switch in the AUTO position, and press the standby button. The light will extinguish, indicating that the unit has resumed the normal operating mode.

Step 4

When the unit cycles off, remove the hopper cover, and place the feed tube in its original position.

Step 5

Replace the hopper cover.



IMPORTANT: The STANDBY mode must *not* be used in lieu of daily disassembly, cleaning, and sanitizing.

Closing Procedure

To disassemble the freezer, the following items will be needed:

- Two cleaning pails
- Sanitized stainless steel rerun can with lid
- Necessary brushes (provided with freezer)
- Cleaner
- Single service towels

Draining Product From the Freezing Cylinder

Step 1

Place the toggle switch in the OFF position as far ahead of cleaning time as possible to allow frozen product to soften for easier cleaning.

Step 2

Lift the hopper cover, remove the feed tube and the mix level float. Take these parts to the sink for cleaning.

Step 3

With a sanitized pail beneath the door spout, place the toggle switch in the WASH position and open the draw valve. When all the product stops flowing from the door spout, close the draw valve. Place the toggle switch in the OFF position. If local health codes permit, empty the rerun into a sanitized stainless steel rerun can. Cover the container and place it in the refrigerator or cooler.



ALWAYS FOLLOW LOCAL HEALTH CODES.

Rinsing

Step 1

Pour one gallon (3.8 liters) of **cool**, clean water into the mix hopper. With the brushes provided, scrub the mix hopper, mix level float stem and mix inlet hole.

Step 2

With a pail beneath the door spout, place the toggle switch in the WASH position and open the draw valve. Drain all the rinse water from the freezing cylinder. When the rinse water stops flowing from the door spout, close the draw valve and place the toggle switch in the OFF position.

Repeat this procedure until the rinse water being drawn from the freezing cylinder is **clear**.

Cleaning

Step 1

Prepare one gallon (3.8 liters) of an approved cleaning solution (example: Kay-5®). USE WARM WATER AND FOLLOW THE MANUFACTURER'S SPECIFICATIONS.

Step 2

Pour the one gallon (3.8 liters) of cleaning solution into the mix hopper and allow it to flow into the freezing cylinder.

Step 3

While the solution is flowing into the freezing cylinder, brush clean the mix hopper, mix level float stem and mix inlet hole.

Step 4

Place the toggle switch in the WASH position. This will cause the cleaning solution in the freezing cylinder to be agitated.

Step 5

Place an empty pail beneath the door spout and open the draw valve. Draw off all the cleaning solution. When the solution stops flowing from the door spout, close the draw valve and place the toggle switch in the OFF position.

Disassembly

Step 1



Be Sure the Toggle Switch is in the "OFF" Position to Eliminate the Chance of Moving Parts.

Step 2

Remove the handscrews and freezer door. Remove the beater assembly from the freezing cylinder and take these parts to the sink for cleaning.

Step 3

Remove the splash shield from the freezer and take to the sink for cleaning.

Step 4

Remove the rear drip pan from the front panel. Take it to the sink for cleaning.

Note: If the drip pan is filled with an excessive amount of mix, this is an indication that the drive shaft o-ring of the beater assembly should be replaced or lubricated properly.

Brush Cleaning

Step 1

Prepare a sink with an approved cleaning solution (example: Kay-5®). USE WARM WATER AND FOLLOW THE MANUFACTURER'S SPECIFICATIONS. **(IMPORTANT:** Follow the label directions. A STRONG solution can cause parts damage. A MILD solution will not provide adequate cleaning.) Make sure all brushes provided with the freezer are available for brush cleaning.

Step 2

Remove the o-ring from the drive shaft of the beater assembly.

Note: To remove o-rings, use a towel to grasp the o-ring. Apply pressure in an upward direction until the o-ring pops out of its groove. With the other hand, push the top of the o-ring forward, and it will roll out of the groove and can be easily removed. If there is more than one o-ring to be removed, always remove the rear o-ring first. This will allow the o-ring to slide over the forward rings without falling into the open grooves.

Step 3

From the freezer door, remove the design cap, draw valve handle, valve lifter arm, and draw valve. Remove all o-rings.

Step 4

Remove the large o-ring, the front bearing, and the guide bearing from the back of the freezer door.

Step 5

Thoroughly brush clean all disassembled parts in the cleaning solution, making sure all lubricant and mix film is removed. Take particular care to brush clean the draw valve core in the freezer door. Place all the cleaned parts on a clean, dry surface to air dry overnight.

Step 6

Return to the freezer with a small amount of cleaning solution. With the black bristle brush, brush clean the rear shell bearing at the back of the freezing cylinder.

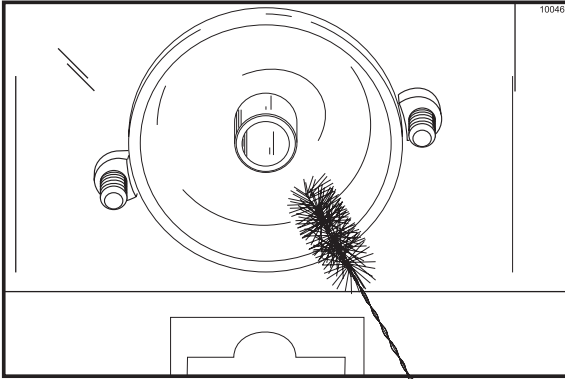

Figure 27

Step 7

Clean all exterior surfaces of the freezer.

Section 7 Important: Operator Checklist

During Cleaning and Sanitizing:

Cleaning and sanitizing schedules are governed by your State or local regulatory agencies and must be followed accordingly. The following check points should be stressed during the cleaning and sanitizing operations.



WE RECOMMEND DAILY CLEANING AND SANITIZING.



ALWAYS FOLLOW LOCAL HEALTH CODES.

Troubleshooting Bacterial Count:

- 1. Thoroughly clean and sanitize machine regularly, including complete disassembly and brush cleaning.
- 2. Use all brushes supplied for thorough cleaning. The brushes are specially designed to reach all mix passageways.
- 3. Use the smaller white bristle brush to clean the mix inlet hole which extends from the mix hopper down to the rear of the freezing cylinder.
- 4. Use the black bristle brush to thoroughly clean the rear shell bearing located at the rear of the freezing cylinder. Be sure to have a generous amount of cleaning solution on the brush.
- 5. IF LOCAL HEALTH CODES PERMIT THE USE OF RERUN, make sure the mix rerun is stored in a sanitized, covered stainless steel container and used the following day. DO NOT prime the machine with rerun. When using rerun, skim off the foam and discard; then mix

the rerun with fresh mix in a ratio of 50/50 during the day's operation.

- 6. On a designated day of the week, run the mix as low as feasible and discard after closing. This will break the rerun cycle and reduce the possibility of high bacteria counts.
- 7. Properly prepare the cleaning and sanitizing solutions. Read and follow label directions carefully. Too strong of a solution may damage the parts and too weak of a solution will not do an adequate job of cleaning or sanitizing.
- 8. Temperature of mix in mix hopper and walk-in cooler should be below 40°F. (4.4°C.).

Regular Maintenance Checks:

- 1. Check the rear shell bearing for signs of wear (excessive mix leakage in rear drip pan). Verify that it has been cleaned properly.
- 2. Using a screwdriver and cloth towel, keep the rear shell bearing and the female hex drive socket clean and free of lubricant and mix deposits.
- 3. Dispose of o-rings and seals if they are worn, torn, or fit too loosely. Replace these o-rings with new ones.
- 4. Follow all lubricating procedures as outlined in "Assembly".
- 5. Check the condenser for accumulation of dirt and lint. A dirty condenser will reduce the efficiency and capacity of the machine. Condensers should be cleaned **monthly** with a soft brush.



Never use screwdrivers or other metal probes to clean between the fins.

Winter Storage

If the place of business is to be closed during the winter months, it is important to protect the freezer by following certain precautions, particularly if the building is subject to freezing conditions.

Disconnect the freezer from the main power source to prevent possible electrical damage.

Your local Taylor Distributor can perform this service for you.

Wrap detachable parts of the freezer such as beater, blades, drive shaft, and freezer door, and place in a protected dry place. Rubber trim parts and gaskets can be protected by wrapping with moisture-proof paper. All parts should be thoroughly cleaned of dried mix or lubrication accumulations which attract mice and other vermin.

Section 8

Troubleshooting Guide

PROBLEM	PROBABLE CAUSE	REMEDY	PAGE REF.
1. No product being dispensed.	a. Toggle switch in OFF position.	a. Place toggle switch in the AUTO position.	12
	b. Inadequate level of mix in mix hopper.	b. Fill mix hopper with mix.	12
	c. Beater motor overloaded.	c. Place the toggle switch in the OFF position. Allow the motor to cool. Reset beater motor. Place the toggle switch in the AUTO position.	5
	d. Unit unplugged at wall receptacle.	d. Plug in power cord.	---
	e. Tripped circuit breaker or blown fuse.	e. Place the circuit breaker in the ON position or replace fuse.	---
	f. Freezer door was assembled incorrectly.	f. See "Operating Procedures" for proper installation.	7
	g. Product is being drawn off far in excess of freezer's capacity.	g. Stop drawing product and allow unit to recover.	---
	h. Feed tube incorrectly installed.	h. Install feed tube according to instructions in this manual.	13
2. Machine will not operate in the AUTO position.	a. Unit unplugged.	a. Plug in power cord.	---
	b. Circuit breaker tripped or fuse blown.	b. Place the circuit breaker in the ON position or replace fuse.	---
	c. Beater motor overloaded, causing a loss of power to the toggle switch.	c. Place the toggle switch in the OFF position. Allow the motor to cool. Reset beater motor. Place toggle switch in the AUTO position.	5
3. Product is too stiff.	a. The temperature control is set too cold.	a. Call service technician.	---

PROBLEM	PROBABLE CAUSE	REMEDY	PAGE REF.
4. Product is too soft.	a. The temperature control is set too warm.	a. Call service technician.	- - -
	b. The feed tube is not installed.	b. Install the feed tube in mix inlet hole at bottom of the mix hopper. (The metering hole should be at the bottom of the tube.)	12/ 13
	c. Out-drawing the freezer's capacity.	c. Two 4 oz. (113.4 gram) servings in one minute.	- - -
5. The freezing cylinder walls are scored.	a. Operating freezer without front bearing on freezer door.	a. Install front bearing on freezer door.	8
	b. Rear bearing unit is out of alignment.	b. Contact service technician.	- - -
6. Excessive leakage in rear drip pan.	a. Worn or defective o-ring on beater drive shaft.	a. Replace every 3 months.	20
	b. Worn rear shell bearing.	b. Contact service technician.	- - -
	c. Incorrect lubricant.	c. Use food grade lubricant (example: Taylor Lube).	7
	d. Inadequate lubrication of beater drive shaft.	d. Lubricate properly.	7
7. Draw valve leaking.	a. Incorrect lubricant.	a. Use food grade lubricant (example: Taylor Lube).	8
	b. Worn or defective o-rings on draw valve.	b. Replace every 3 months.	20
	c. Inadequate lubrication of draw valve.	c. Lubricate properly.	8
8. Product not feeding into freezing cylinder.	a. Inadequate level of mix in mix hopper.	a. Fill mix hopper with mix.	12
	b. Mix inlet hole frozen up.	b. Call service technician.	- - -
	c. Feed tube incorrectly installed.	c. Place feed hole at the bottom.	12
9. Unit goes out on overload excessively.	a. Too many appliances plugged into the circuit.	a. A separate 15 amp. circuit is needed for the freezer to operate properly.	- - -
	b. Extension cord placed between power cord and wall receptacle.	b. If extension cord is used, it must match the power cord in size of wire ampacity.	- - -

Section 9

Parts Replacement Schedule

PART DESCRIPTION	EVERY 3 MONTHS	EVERY 6 MONTHS	ANNUALLY	QUANTITIES TO BE REPLACED
Beater Drive Shaft O-Ring	X			1
Freezer Door O-Ring	X			1
Freezer Door Front Bearing	X			1
Freezer Door Guide Bearing	X			1
Draw Valve O-Ring	X			2
Draw Valve Handle O-Ring	X			1
Black Bristle Brush, 1" x 2"		Inspect & Replace if Necessary	Minimum	1
Double Ended Brush		Inspect & Replace if Necessary	Minimum	1
White Bristle Brush, 3" x 7"		Inspect & Replace if Necessary	Minimum	1

Refer to Parts List on the next page when ordering the above parts.

Section 10

Parts List

J5052919/Up HP62 - w/Standby

DESCRIPTION	PART NUMBER	142 QTY.	WARR. CLASS	REMARKS	PARTS UPDATE
BEARING-FRONT	023262	1	000		
BEARING-GUIDE	014496	1	000		
BEARING-REAR SHELL *150-52-68*	023648	1	000		
+COLLAR-REAR BEARING *150-2-68*	025564	1	000		
+NUT-REAR BEARING *150-52-68*	023647	1	000		
+TAB-BEARING LOCK *150-2-68*	025027	1	000		
BEARING-UNIT REAR	024764	1	103		
+COUPLING-SERVICE	034147	1	103	FOR REAR BEARING UNIT - 024764	
BEATER A. *150-2-162-168*	X24689	1	103		
+O-RING-13/16 OD X .139W	021278	1	000		
BELT-HTD PITCH LENGTH 565MM	041585	1	000	COGGED - IDLER PULLEY TO BEARING UNIT	
BELT-V-4L370	004227	1	000	LARGE PULLEY TO BEATER MOTOR	
BLOCK-TERMINAL 5 POLE	024329	1	0103		
BRUSH-DOUBLE ENDED-PUMP&FEED T	013072	1	000		
BRUSH-MIX PUMP BODY-3"X7"WHITE	023316	1	000		
BRUSH-REAR BRG 1IN.DX2IN.LGX14	013071	1	000		
CAP-DESIGN-1.010"ID-6 POINT	014218	1	000		
COMPRESSOR - TECUMSEH	049302-	1	512	HP 62 - J6012926/UP	101
+CAPACITOR-RUN	023739	1	212	115 VOLT	101
+CAPACITOR-START	039557-27	1	212	115 VOLT	101
+RELAY-START-COMPRESSOR	045432-12	1	212	115 VOLT	101
+CAPACITOR-RUN	027087	1	212	208-230 VOLT	101
+CAPACITOR-START	039567	1	212	208-230 VOLT	101
+RELAY-START-COMPRESSOR	048150	1	212	208-230 VOLT	101
COMPRESSOR - TECUMSEH	048628-	1	512	HP62 - J5052919 thru J6012925	
+CAPACITOR-RUN- 25UF/370VAC	023739	1	103	115 VOLT	
+CAPACITOR-START- 72-88UF/250V	039557-27	1	103	115 VOLT	
+RELAY-START-COMPRESSOR	045432-12	1	103	115 VOLT	
+CAPACITOR-RUN- 15UF/370V	027087	1	103	208-230 VOLT	
+CAPACITOR-START- 72-88UF/	039567	1	103	208-230 VOLT	
+RELAY-START-COMPRESSOR	048150	1	103	208-230 VOLT	
+GROMMET-COMPRESSOR MOUNT-AE-AK	039919	4	000		

+ Available Separately

DESCRIPTION	PART NUMBER	142 QTY.	WARR. CLASS	REMARKS	PARTS UPDATE
+SLEEVE-MOUNTING-COMP-AE	039920	4	000		
CONDENSER-AC-12LX16HX2.5T3ROW	048935	1	103		
CORD-POWER	085093	1	103	115 VOLT - 1 PHASE	
COVER A.-HOPPER	X49633	1	103	J6010000/UP (REPLACES 039445)	118
DECAL-CLEAN INST.-HOPPER	019029	1	000		
DECAL-MAG-FLAVOR PADS	039713	1	000		
DECAL-MAG-FROZEN YOGURT	039717	1	000		
DECAL-MAG-SOFT SERVE	039714	1	000		
DECAL-TROUBLESHOOTING	038374	1	000		
DIAGRAM-WIRING *142*	049264	1	000		
DOOR-1 SPOUT-4" LONG	X38959-SER	1	103		
+O-RING-2-3/4 OD X .139W	019998	1	000		
+ARM-VALVE LIFTER	024761	1	103		
+HANDLE-DRAW	024762	1	103		
+O-RING-3/4 OD X .103W	015835	1	000		
+VALVE-DRAW *150-2*	024763	1	103		
+O-RING-7/8 OD X .103W	014402	2	000		
DRYER-FILTER 1/4 X 1/4 SOLDER	048878	2	000		
FLOAT A.-MIX LEVEL *142*	X39690	1	103		
GUIDE A.-DRIP PAN *142*	X43491	1	103		
HARNES-WIRE-UPPER-HI VOLT	043581	1	103	INCLUDES 039534 TOGGLE SWITCH	
KIT A.-TUNE UP*150-152*	X25802	1	000		
+BEARING-FRONT	023262	1	000		
+BEARING-GUIDE	014496	1	000		
+CAP-DESIGN-1.010"ID-6 POINT	014218	1	000		
+O-RING-13/16 OD X .139W	021278	1	000		
+O-RING-2-3/4 OD X .139W	019998	1	000		
+O-RING-3/4 OD X .103W	015835	1	000		
+O-RING-7/8 OD X .103W	014402	2	000		
+TOOL- 0-RING REMOVAL	048260-WHT	1	000		
LABEL-WARNING-COVER	051433	4	000	PANELS & BOX COVER	
LEG-4"-3/8-16 STUD-PLASTIC	024755	4	103		
LIGHT-MIX LOW-AMBER ROUND-24V	039708	1	103	MIX LOW	

+ Available Separately

DESCRIPTION	PART NUMBER	142 QTY.	WARR. CLASS	REMARKS	PARTS UPDATE
LUBRICANT-TAYLOR 4 OZ.	047518	1	000		
MAN-OPER 142	039709-M	1	000		
MOTOR-BEATER	039563-	1	212		
MOTOR-FAN 50 WATT	029770-	1	103		
+FAN-5 BLADE 12" PUSH 22DEG CCW	049009	1	103		
NUT-STUD *150-152-162-168*	034829	2	103	HANDSCREW	
PAN A.-WHITE FRONT DRIP**142*	X43474	1	103	J0125321/UP (Replaces Side Mt - 039635)	41
PANEL-FRONT-PLASTIC	042933	1	103		
PANEL-REAR *142*STANDBY	049001	1	103		
PANEL-SIDE *142* RIGHT	048879	1	103		
PANEL-SIDE *142*LEFT	048999	1	103		
PCB A.-STANDBY CONTROL-HOPPER	X44803SER1	1	212	115 VOLT	
PCB A.-STANDBY CONTROL-HOPPER	X44803SER2	1	212	208-230 VOLT	
PLATE A.-MOUNTING DECAL *142*	X39629	1	103	DEC PLATE	
PROBE-THERMISTOR-BARREL-2% TOL	038061-BLK	1	103	BARREL	
PROBE-THERMISTOR-HOPPER-2% TOL	039470-BLK	1	103	HOPPER	
PULLEY-10"OD W/TIMING GEAR**142	046194	1	103	INCLUDES IDLER PULLEY AND BOLT	
+BOLT-IDLER-1/2 X 20	039620	1	103	AVAILABLE FOR SERVICE	
+NUT-SHAFT JACK *142*	039616	1	103		
+WASHER-PULLEY IDLER *142*	039615	1	103		
PULLEY-AK17X 5/8	031076	1	103	BEATER MOTOR	
PULLEY-HTD 72 TOOTH 5MM PITCH	041095	1	103	BEARING UNIT	
RELAY-3 POLE-24 AMP-120 VAC	039538-	1	103	MAIN	
SANITIZER KAY-5 125 PACKETS	041082	1	000		
SENSOR A.-MIX LEVEL	X39688	1	103		
SHELL A.-INSULATED *142*HOOD	X49175	1	512		
+STUD-NOSE CONE *142*	042168	2	103		
SHIELD-SPLASH-PLASTIC	039444	1	103		
SHROUD-FAN *142*	048877	1	103		
SWITCH A.-DRAW *142*	X43577-SER	1	103		
BEARING-SWITCH	029244	2	000		
BRACKET-DRAW SWITCH	041063	1	103		
E-RING-1/4 IN-ZD	034962	1	000		

+ Available Separately

DESCRIPTION	PART NUMBER	142 QTY.	WARR. CLASS	REMARKS	PARTS UPDATE
ROD-SWITCH-SQUARE *142*	039617	1	103		
SPRING-COMP.720X.063X2.00	023664	1	103		
SWITCH-ACTUATOR	035609	1	103		
SWITCH-LEVER-SPDT-15A-125-250V	027214	1	103		
SWITCH-PRESSURE 440 PSI-SOLDER	048230	1	103		
SWITCH-STAND BY SPST-LIGHTED	043279	1	103		
+BULB-LIGHT 14V 142	043279-1	1	000		
SWITCH-TOGGLE	039534	1	103	POWER SWITCH (SEE HARNESS-WIRE)	
TUBE-CAPILLARY .049 X 7FT	049172	1	103		
TUBE-FEED-150-DANFOSS-.166HOLE	035819	1	103		
VALVE-ACCESS 1/4FL X 1/4SOLDER	044404	1	103	SUCTION LINE	
VALVE-ACCESS 1/4FL X 3/8SDR-90	044455	1	103	MAIN COMPRESSOR	
VALVE-ACCESS-1/4 MFLX1/4 S-90	047016	1	103	COMPRESSOR HIGH SIDE	
VALVE-EPR 1/4S	022665	1	103	SUCTION LINE	
VALVE-EXP-THERMO-1/4S X 1/4FPT	051578	1	103	(REPLACES 018217-1)	119
+BOOT-EXPANSION VALVE	027137	1	000		
VALVE-SOLENOID 1/2ORF X 1/2ODF	043681-	1	103	SUCTION LINE	
VALVE-SOLENOID 7/64ORF X 1/4S	043449-	2	103	LIQUID LINE	
VIDEO-TRAIN FILM-SS-TAYLORMATE	037665-V	1	000		

+ Available Separately

DESCRIPTION	PART NUMBER	142 QTY.	WARR. CLASS	REMARKS	PARTS UPDATE
50Hz					
COMPRESSOR - TECUMSEH	049302-40	1	512	J6012926/JP	101
+CAPACITOR-RUN	027087	1	212		101
+CAPACITOR-START	039567	1	212		101
+RELAY-START-COMPRESSOR	041064	2	212		101
COMPRESSOR AK9462Z	048628-40	1	512	J5052919 thru J6012925	
+CAPACITOR-RUN - 15UF/370V	027087	1	103		
+CAPACITOR-START- 72-88UF/	039567	1	103		
+RELAY-START-COMPRESSOR	041064	1	103		
CORD-POWER-250V-15A-95"L	042936-27	1	103		
MOTOR-BEATER	039563-34	1	212		
+SWITCH-CENTRIFUGAL-MOTOR START	039563-001	1	212	50 Hz Only	119
PANEL-SIDE *142* LEFT 50HZ	049003	1	103		
PULLEY-AK20X5/8	041162	1	103		
VIDEO-TRAIN FILM-SS-TAYLOR	037665-PAL	1	000		

+ Available Separately

N - 115V
 N - 220/240V 50HZ
 L2 - 208/230V 60HZ

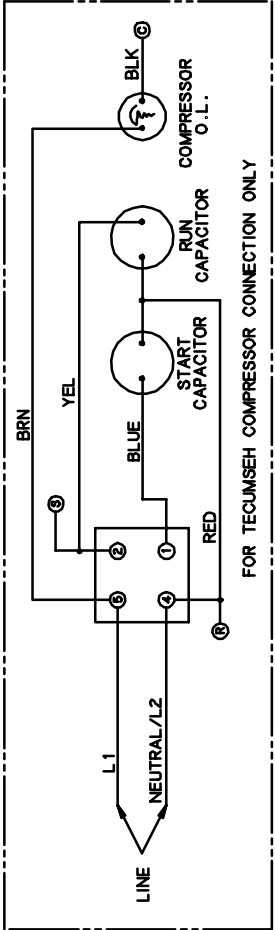
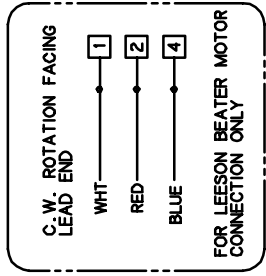
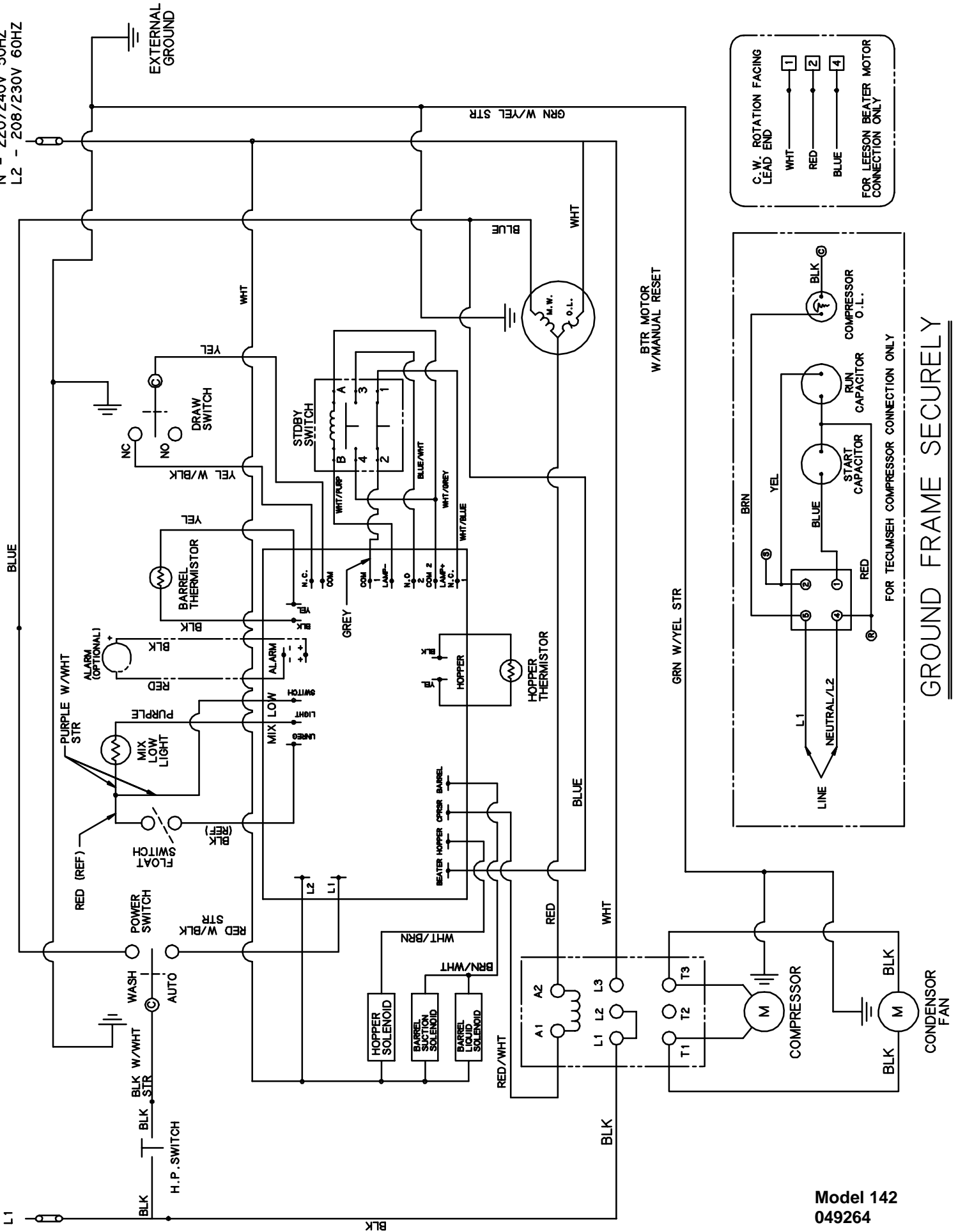

GROUND FRAME SECURELY

Model 142
 049264